

PXI-3950/3920/3910

Next-generation 3U PXI™ Controllers for Hybrid PXI-based Testing Systems



Features

- PXI™ specification Rev. 2.2 Compliant
- Scalable computing power
 - Intel® Core™2 Duo T7500 2.2 GHz processor (PXI-3950)
 - Intel® Pentium® M 760 2.0 GHz processor (PXI-3920)
 - Intel® Celeron® M 373 1.0 GHz processor (PXI-3910)
- On-board DDR2 memory
 - Up to 4 GB 667 MHz (PXI-3950)
 - 512 MB 400/533 MHz soldered (PXI- 3920/3910)
- Integrated SATA hard drive
 - 160 GB 7200 RPM (PXI-3950)
 - 80 GB 5400 RPM (PXI-3920/3910)
- CompactFlash® socket for HDD replacement
- Integrated I/O
 - Dual Gigabit Ethernet ports
 - Four USB 2.0 ports
 - Built-in GPIB (IEEE488) controller
 - Two RS-232/422/485 ports
 - DVI-I video connector
 - High definition audio output and input
 - Trigger I/O for advanced PXI™ trigger functions
- Programmable watchdog timer

Introduction

The ADLINK PXI-3900 series of next-generation PXI™ embedded controllers is based on the Intel® Celeron® M, Intel® Pentium® M, or Intel® Core™2 Duo and specifically designed for hybrid PXI-based testing systems by providing a rugged and stable operating environment for a variety test and measurement applications.

Hybrid PXI-based testing systems are typically composed of a PXI platform and diversified stand-alone instruments for complex testing tasks. The PXI-3900 series provides plenty of interfaces, including GPIB, USB, and COM ports, for connecting and controlling instruments. The PXI-3900 series also provides dual Gigabit Ethernet ports—one for a LAN connection and the other for controlling next-generation LXI instruments.

Combining state-of-art Intel® Core™2 Duo T7500 2.2 GHz processor, the latest GME965 chipset, and 4 GB of 667 MHz DDR2 memory, the PXI-3950 provides two computing engines on a single processor that can execute two independent tasks at the same time in a multi-tasking environment. The PXI-3920 and PXI-3910 are meticulously designed to provide maximum robustness. The CPU and memory chips are soldered on the PCB to increase reliability in shock and vibration prone environments. The aluminum-copper composite heat sink helps to disperse heat uniformly to maintain a stable operating temperature.

Combining a variety of instrument control interfaces and reliable mechanical and electronic design, the ADLINK PXI-3900 series is well qualified to meet the needs of your hybrid PXI-based testing systems.

Notice

These PXI™ controllers implement rear I/O. PXI™ controllers with rear I/O are designed to operate with a matching rear transition module which provides internal or external chassis I/O.

Warning

If these PXI™ controllers are used with a chassis that contains a rear transition module that does not match the controller, the rear I/O functionality may not operate and may cause damage to the PXI™ controller or the rear transition module.

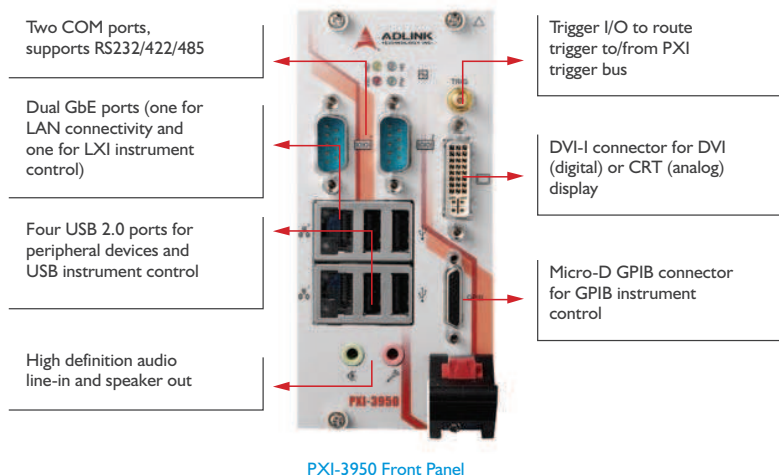

Specifications

Model Name	PXI-3910	PXI-3920	PXI-3950
Core Features			
CPU	Intel® Celeron® M 373 1.0 GHz	Intel® Pentium® M 760 2.0 GHz	Intel® Core™2 Duo T7500 2.2 GHz
FSB	400 MHz	533 MHz	800 MHz
Chipset	Intel® 915 GME Graphic Memory Control HUB Intel® I/O Controller Hub 6 Mobile (ICH6-M)		Intel® GME965 Graphic Memory Control HUB Intel® I/O Controller Hub 8 Mobile (ICH8-M)
Memory	512 MB on-board soldered memory One DDR2 SO-DIMM socket for memory expansion Supports dual-channel DDR2 SDRAM, 400/533 MHz		4 GB SO-DIMM memory Supports dual-channel DDR2 SDRAM, 667 MHz
Display			
Chipset	Intel® GMA 900 graphic media accelerator		Intel® GMA X3100 graphic media accelerator
DVI	Single channel TMDS via SDVO to DVI controller up to 1600 x 1200 resolution @ 60 Hz		
CRT	Analog CRT route to DVI-I connector on the faceplate up to 1280 x 1024 resolution		
LVDS (For rear I/O only)	Single 18-bit LVDS channel route to rear transition module Supports LCD backlight control		
Interface	DVI-I connector for digital or analog video signal outputs		
I/O Connectivity			
Hard Drive	80 GB SATA hard drive, 5400 RPM		160 GB SATA hard drive, 7200 RPM
Ethernet	On board Marvell™ 88E8055 Dual Gigabit Ethernet controllers Two RJ-45 connectors with speed/link/active LED on the faceplate		
USB	4 x USB 2.0 on the faceplate		
GPIO	On-board IEEE488 GPIB controller		
Serial Port	Micro-D 25-pin connector on the faceplate (ACL-IEEE488-MD1 cable required) Two 16C550 UART compatible COM ports on the faceplate		
Audio	Supports RS-232, RS-422 and RS-485, configurable by jumper setting Supports high definition audio input/output Two audio jacks on the faceplate for line-in/mic-in and speaker-out		
Trigger I/O	SMB connector on the faceplate to route an external trigger signal to/from PXI™ trigger bus		
CompactFlash Socket	Type II CF Socket, supporting PIO and DMA modes		
Mechanical and Environmental			
Dimensions	3U PXI™ module 60.5 mm x 128.7 mm x 213.2 mm		
Slot Requirements	1 system slot plus 2 controller expansion slots		
Weight	0.9 kg		
Operating Temp.	0 to 55°C		
Storage Temp.	-20 to 80°C		
Relative Humidity	5 to 95%, non-condensing		
Shock	30 G, half-sine, 11 ms pulse duration		
Vibration	Operating: 5 to 500 Hz, 0.5 G _{RMS} , 3 axes Non-operating: 5 to 500 Hz, 2.46 G _{RMS} , 3 axes		
Emissions Compliance	EN 61326-1 FCC Class A		
CE Compliance	Immunity: EN 61326-1		

Ordering Information

- PXI-3950**
 3U PXI Core™2 Duo T7500 2.2 GHz System Controller with 4 GB Memory & 160 GB HDD
- PXI-3950/M2G**
 3U PXI Core™2 Duo T7500 2.2 GHz System Controller with 2 GB Memory & 160 GB HDD
- PXI-3920**
 3U PXI Pentium® M 760 2.0 GHz System Controller with 512 MB Memory & 80 GB HDD
- PXI-3920/M1.5G**
 3U PXI Pentium® M 760 2.0 GHz System Controller with 1.5 GB Memory & 80 GB HDD

- PXI-3910**
 3U PXI Celeron® M 373 1.0 GHz System Controller with 512 MB memory & 80 GB HDD
- ACL-IEEE488-MD1**
 25-pin Micro-D to GPIB Cable, 1 Meter Length

Cable Accessory

